

Product information sheet ETAGON 500-U

Item no. 522227

Benefits



- Generous staggered bowl with the functionality of a sink centre
- Integrated step creates an additional functions level
- Innovative system concept with versatile ETAGON rails
- High-quality features with the covered C-overflow™ and InFino™ drain system – elegantly integrated and extremely easy-care
- For undermount installation, ideal in combination with high-quality worktops

Colours

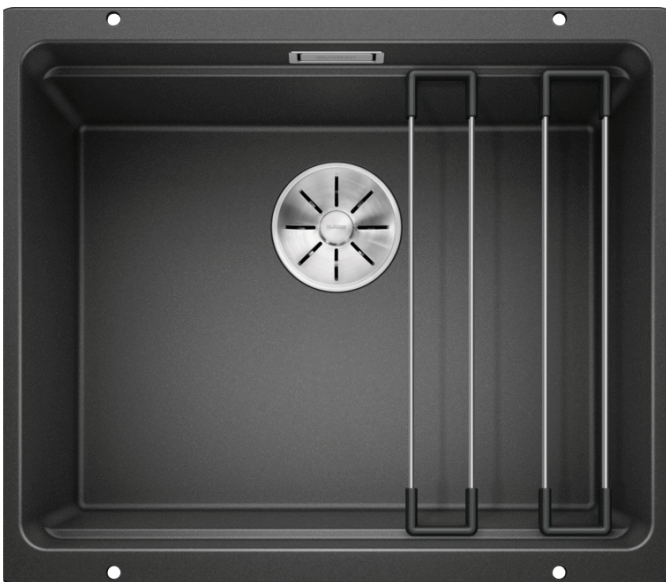

Available colours:

anthracite
rock grey
alu metallic
pearl grey
white
jasmine
champagne
tartufo
nutmeg
coffee

SILGRANIT™ PuraDur™ anthracite

Planning information

- See p. 381 for the flexible sealing tape required for installing a kitchen mixer tap, drain remote control or soap dispenser in laminate worktops.
- Cut-out information for all of the installation processes can be found in our internet download.

Scope of supply

- 2 x ETAGON rails in stainless steel, waste kit with space-saving pipe, 3 1/2" InFino™ basket strainer, fixing kit

234164 - Two ETAGON rails

Details

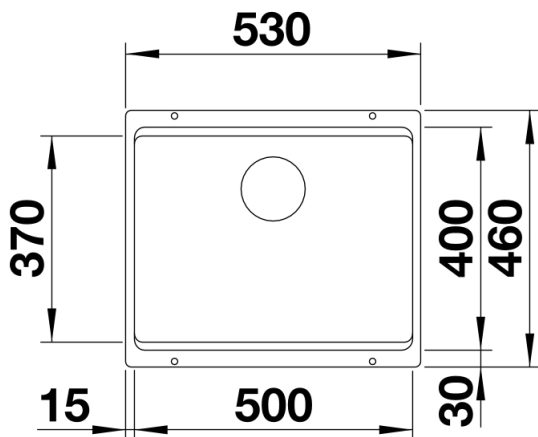

Top view

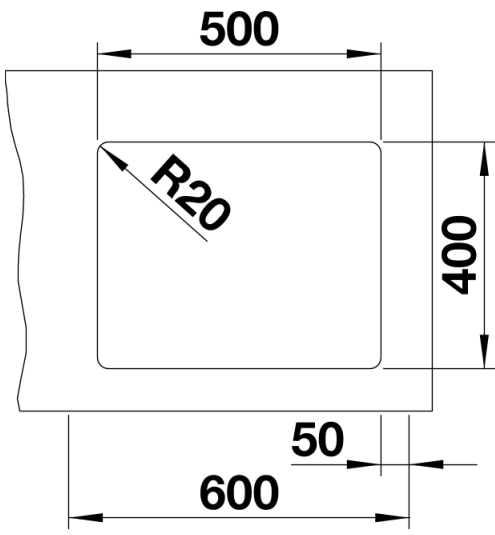

Cut-out

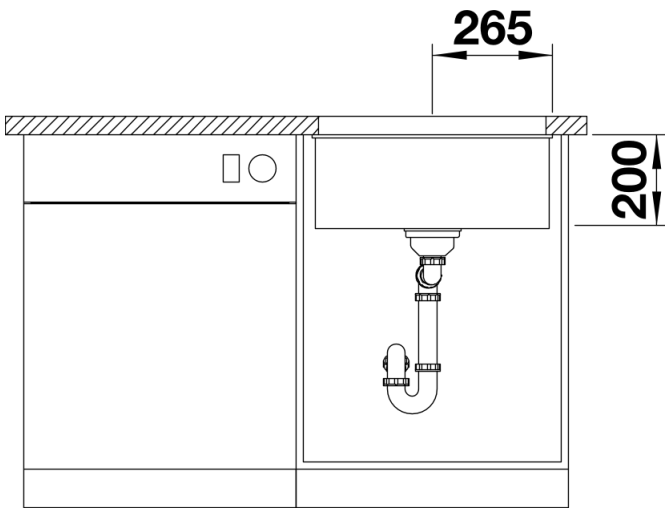

Front view

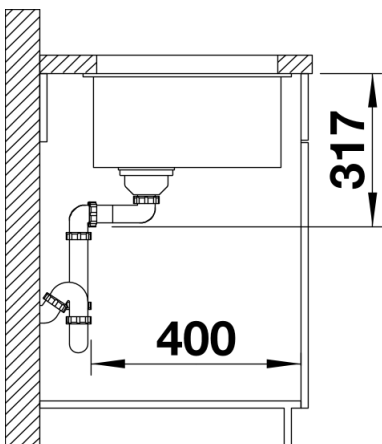

Side view